



# ACX 6X4

## ACX 6X4

Representative ACX  
Key Specifications. Your truck  
will be custom-engineered  
for your application

**ALL DIMENSIONS IN INCHES**

ACX 6x4 Typical  
Cummins L9 Engine  
Allison 4500  
Meritor 20K Steer Axle  
Meritor RT46 Rear Axle  
Hendrickson HMX 46K  
Rear Suspension  
210" Wheelbase  
62" Overhang

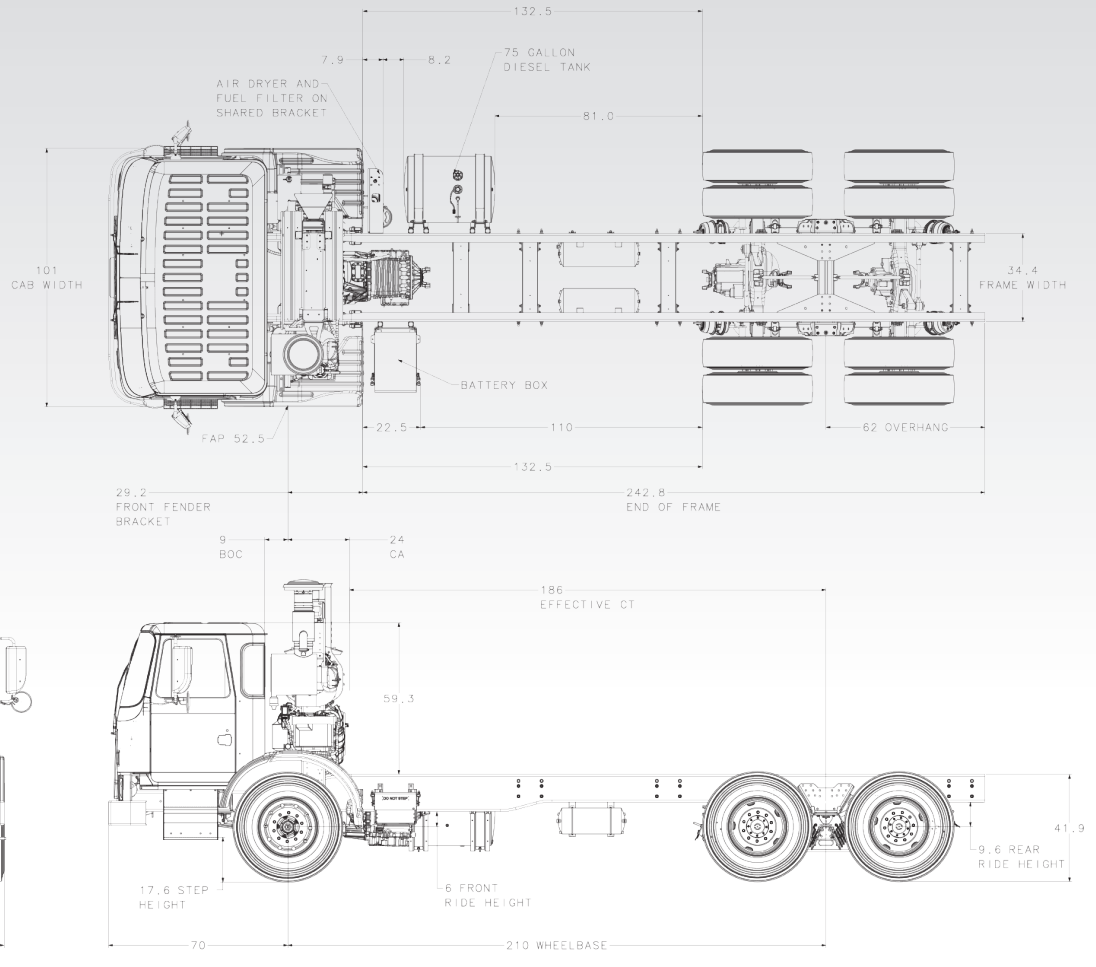

## ENGINE AND EQUIPMENT

ENGINE AND EQUIPMENT	
Engine model	Cummins 2021 L9 rated from 300 hp to 380 hp
	Cummins 2021 X12 rated from 350 hp to 500 hp
	Cummins L9N (natural gas) rated from 300 hp to 320 hp
Exhaust (Diesel)	Cummins ISX12N (natural gas) rated at 330 to 350 hp
	Horizontally mounted SMA (single module aftertreatment) with LHVE (left hand vertical exhaust)
Exhaust (Gas)	Horizontally mounted SMA (single module aftertreatment) with RHVE (right hand vertical exhaust)
	Horizontally mounted 3-way catalyst on BOC with LHVE (Left hand vertical exhaust)
	Horizontally mounted 3-way catalyst on BOC with RHVE (Right hand vertical exhaust)
	Horizontally mounted 3-way catalyst on frame rail with RHUFE (Right hand under frame exhaust) (L9N only)

ENGINE AND EQUIPMENT (CONTINUED)	
Air cleaner	15 inch single stage EPG
	15 inch single stage with safety element EPG
Radiator	16 inch 2 stage
	1300 sq. inch aluminum
Fan & drive	1118 sq. inch bar plate
	2-speed fan drive
	On/Off fan drive
	Variable speed fan drive
	Electrical operated cooling fans - CNG available, Diesel to be released in 2021
Coolant hoses/piping	Silicone hoses with constant tension clamps
Coolant	Extended life coolant

# TRANSMISSION AND EQUIPMENT

TRANSMISSION AND EQUIPMENT	
Transmission model	Allison 3000 RDS (not available with X12 or ISX12N)
	Allison 4000RDS
Transmission gearing	5 or 6-speed
Transmission controls	Allison push button
Transmission cooler	Remote mounted oil to coolant layered core oil cooler
Transmission lubricant	TES 295 Allison approved synthetic auto trans fluid
Driveshaft	Dana Spicer® half-round, yoke size 1710, 1760 or 1810 dependent on transmissions and driveline rotational speeds

# FRONT AXLE AND EQUIPMENT

FRONT AXLE AND EQUIPMENT	
Axle model	Meritor MFS-20
	Meritor MFS-18
	Meritor MFS-16
	Dana D-2200W
Front suspension	Hendrickson Steertek 20K
	7,500 lb Flat leaf rated at 16,500 lb capacity
	8,500 lb Flat leaf rated at 18,800 lb capacity
	9,500 lb Low camber flat leaf rated at 20,800 lb capacity
	10,100 lb Flat leaf rated at 22,000 lb capacity
	10,200 lb Taper leaf rated at 22,000 lb capacity
Power steering	Hendrickson 20K taper leaf front suspension (Only available with Steertek axle)
	Sheppard M100PPV3 with assist ram
Brakes	Meritor 16.5 x 6 QP
	Meritor 16.5 x 7 QP
	Meritor 16.5 x 7 QP
	Meritor 16.5 x 7 SSQ
	Meritor EX225H2 air disc

# REAR AXLE AND EQUIPMENT

REAR AXLE AND EQUIPMENT	
Axle model	Meritor MT40-14X
	Meritor MT40-14X with 1/2 inch housing
	Meritor MT44-14X
	Meritor MT46-160
	Meritor MT46-164 EH
	Meritor RT52-185
Rear axle ratio	4.89 to 6.14 Dependent on axle model, vehicle configuration and application
Rear suspension	Haulmaax HMX-EX 400 at a 54 inch axle spread, rated at 40,000 lb capacity
	Haulmaax HMX-EX 460 at a 54 inch axle spread, rated at 40,000 lb capacity
	HN522 at a 54 inch axle spread, rated at 52,000 lb capacity
	Primaax EX-462 Air Ride at a 54 inch axle spread, rated at 46,000 lb capacity
Brakes	Meritor 16.5 x 7 QP
	Meritor 16.5 x 7 QS
	Meritor 16.5 x 8.62 QP
	Meritor 16.5 x 8.62 SSQ
	Meritor 16.5 x 7 BGS
	Meritor EX225H2 air disc

# CHASSIS AND EQUIPMENT

CHASSIS AND EQUIPMENT	
Wheelbase	Available in 3 inch increments between 144 inch and 264 inch
Frame	3/8 inch Variable drop rail, 120 kPsi heat treated steel, RBM of 3,259,000 lb. in to 4,220,000 lb. in dependent on drop configuration and liners
Heavy-duty front end	Available for severe duty service applications such as snow plowing
Tow device	Two tow pins integral with front crossmember

# CAB AND EQUIPMENT

CAB AND EQUIPMENT	
Cab construction	The cab is constructed from corrosion-resistant steel followed by a Cathodic Electrocoat dip process before the top coat is applied
Cab drive configuration	Single LH drive
	Single RH drive
	Dual drive dual sit
	Dual drive RH standup
Cab doors	Single LH drive RH standup
	Steel doors with power or manual crank window regulators
Mirrors	Aluminum fold-up doors for stand-up and low entry options
	Black or chrome plastic housing with dual pane mirrors. Options include power adjustment, heat and integrated marker lights
Cab climate control system	30,000 BTU air conditioner with heater
Steering column	Adjustable for tilt on single drive cab configurations
Steering wheel	16 or 18 inch diameter
Driver seats	National Cush II low back air ride
	Sears C2 air ride
	Sears C2+ air ride
	Sears C2+ air ride with air lumbar support
	Sears C2+ air ride with air lumbar support and headrest
	Various Bostrom selections
Passenger seats	Fixed type low back
	Sears C2 fixed or air ride
	Sears C2+ fixed or air ride
	Sears C2+ air ride with air lumbar support
	Sears C2+ air ride with air lumbar support and headrest
	Various Bostrom selections