

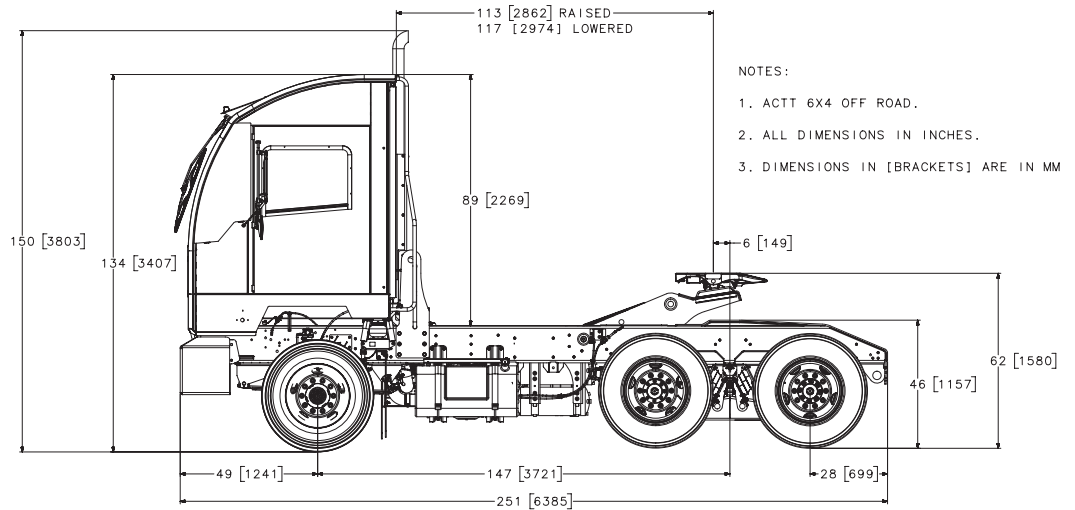

ACTT 6X4

AUTOCAR TERMINAL TRACTOR - OFF-ROAD

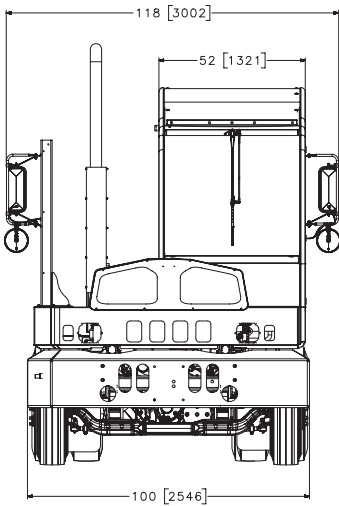

NOTES:

1. ACTT 6X4 OFF ROAD.
2. ALL DIMENSIONS IN INCHES.
3. DIMENSIONS IN [BRACKETS] ARE IN MM

ENGINE AND EQUIPMENT

| | |
|------------------------|--|
| Engine model | Cummins QSBT4f 146HP @ 2100RPM 620 LB-FT @1500RPM |
| | Cummins QSBT4f 164HP @2300RPM/540 LB-FT @1500RPM |
| | Cummins QSBT4f 173HP @2300RPM/620 LB-FT @1500RPM |
| | Cummins QSBT4f 260HP @2500RPM/730 LB-FT @1500RPM |
| | Cummins B6.7 200HP @2600RPM/520 LB-FT @1500RPM |
| | Cummins B6.7 260HP @2600RPM/620 LB-FT @1500RPM |
| | Cummins B6.7N 200HP @2600RPM/520 LB-FT @1500RPM |
| | Cummins B6.7N 240HP @2600RPM/560 LB-FT @1500RPM |
| Exhaust | Vertical DOC w/horizontal SCR |
| | Vertical single module DPF/SCR (Cummins B6.7 only) |
| DEF | 6 gallon DEF tank |
| | 12 gallon DEF tank |
| Air Cleaner | Donaldson 11 inch two stage |
| | Donaldson inline precleaner / Donaldson topspin precleaner |
| Radiator | 850 square inch aluminum |
| Fan & Drive | Direct drive |
| | Viscous fan clutch |
| Coolant Hoses / Piping | Silicone hoses with steel tubing |
| Coolant | Extended life coolant |
| Engine Equipment | Fleetguard FS 1003 F/W separator w/probe & dash light |

CHASSIS AND EQUIPMENT

| | |
|-----------------|--|
| Wheelbase | 146 inch |
| Frame | 2.0 million RBM, 50,000 KSI steel, C-reinforced |
| | 2.0 Million RBM, 50KSI steel, C-reinforced, heavy duty box frame, galvanized coating |
| Frame fasteners | Grade 8 bolts where possible |
| Bumper | Steel reinforced bumper |
| | Heavy duty reinforced bumper |
| Tow device(s) | Front & rear tow eyes |
| | Rear pintle hook |
| Mud flaps | Rear of drive tires |
| Brake system | 121 air brake system, front/rear system protection |

ACTT 6X4 OFF-ROAD

Representative Terminal Tractor Specifications.
Your truck will be custom-engineered for your application

ALL DIMENSIONS IN INCHES

TRANSMISSION AND EQUIPMENT

| | |
|------------------------|------------------------------|
| Transmission model | Allison 3000 RDS |
| | Allison 3500 RDS |
| Transmission gearing | 4-speed |
| | 3-speed |
| Transmission controls | Allison push button |
| | Allison T-handle |
| Transmission cooler | Oil to water type |
| Transmission lubricant | TranSynd™ synthetic |
| Driveshaft | Dana Spicer® 1710 half-round |

FRONT AXLE AND EQUIPMENT

| | |
|--------------------------|--|
| Axle model | Meritor MFS wide track (14,700 lb rated) |
| | Dana Spicer® E-1322-W (13,200 lb rated) |
| Front suspension | Flat leaf (14,500 lb rated) |
| | Flat leaf (18,800 lb rated) |
| Shock absorbers | Double acting - heavy duty |
| Power steering | Gearbox, integral steering w/mechanical backup |
| Power steering reservoir | Integral w/hydraulic tank |
| Brakes | 15 x 4 s-cam |
| | 16.5 x 5 s-cam |
| Brake drums | Cast iron |
| Stack adjusters | Meritor automatic slack adjusters |
| | Haldex slacks |
| Front hubs | Iron hub piloted |

| REAR AXLE AND EQUIPMENT | |
|-------------------------|--|
| Axle model | Meritor MT40-14X (single reduction) |
| Rear axle ratio | 7.17:1 |
| Rear suspension | Hendrickson HN460 54" spread |
| ABS | None (exempt) |
| | 4S4M with and without traction control |
| Brakes | 16.5 x 7 |
| | 16.5 x 8.62 |
| Brake drums | Cast iron |
| Stack adjusters | Meritor automatic slack adjusters |
| | Haldex slacks |
| Rear hubs | Iron hub piloted |
| Gear lubricant | Synthetic |

| CHASSIS AND EQUIPMENT | |
|-----------------------|--|
| Wheelbase | 146 inch |
| Frame | 2.0 million RBM, 50,000 KSI steel, C-reinforced |
| | 2.0 Million RBM, 50KSI steel, C-reinforced, heavy duty box frame, galvanized coating |
| Frame fasteners | Grade 8 bolts where possible |
| Bumper | Steel reinforced bumper |
| | Heavy duty reinforced bumper |
| Tow device(s) | Front & rear tow eyes |
| | Rear pintle hook |
| Mud flaps | Rear of drive tires |
| Brake system | 121 air brake system, front/rear system protection |

| PNEUMATIC SYSTEM | |
|------------------------|---|
| Air compressor | Wabco 18.7 CFM |
| Air system Drain Valve | Manual petcocks all tanks |
| | Air manifold with pull cords in all tanks or 1/4 turn valve tank drains |
| Air lines | Nylon, color coded |
| Brake system | 121 air brake system, front/rear system protection |

| FUEL SYSTEM | |
|-------------|--|
| Fuel tank | 50 gallon steel round mounted left side |
| | 50 gallon step tank |
| | 50 gallon aluminum round |
| | Prep for CNG or LNG tanks (W/Cummins B6.7N option) |
| Fuel filter | Cummins |
| Fuel lines | SAE J844 nylon |

| 5TH WHEEL AND HYDRAULIC SYSTEM | |
|--------------------------------|---|
| 5th wheel | SAF/Holland 80,000 lb semi-oscillating 16 inch lift |
| | SAF/Holland 100,000 lb semi-oscillating 16 inch lift |
| Hydraulic lift cylinders | (2) 5 inch 50,000 lb capacity, upper & lower spherical bushings |
| | Limited lift height cylinders |
| Hydraulic tanks | 15 gallon steel tank w/sight glass |
| Pump | Engine mounted |
| | Chelsea PTO 280-5RK |

| TRAILER EQUIPMENT | |
|---------------------------------|---|
| Air connections | 15 ft straight rubber trailer hoses w/spring hanger |
| | 20 ft straight rubber trailer hoses w/spring hanger |
| 7-way electric cable receptacle | 12 ft electrical cable |
| | 15 ft electrical cable |

| TIRES AND WHEELS | |
|------------------|---|
| Front tires | 295/75R22.5 Low-Pro Double Coin |
| | (11R/280/275)/Goodyear, Michelin, Continental |
| Front wheels | Steel 22.5" x 8.25" hub piloted, 285mm BC |
| | 22.5" x 8.25" Steel 2 HH wheel, customer supplied wheels/tires |
| Rear tires | 295/75R22.55 Double Coin |
| | (11R/280/275)/Goodyear, Michelin, Continental |
| Rear wheels | Steel 22.5" x 8.25" hub piloted, 285mm BC |
| | 22.5" x 8.25" Steel 2 HH wheel, customer supplied wheels/tires V2B flow through valve caps |

| ELECTRICAL SYSTEM | |
|--------------------|--|
| Electrical system | 12V, negative ground |
| Alternator | Delco 160 AMP, 28SI w/remote Sense pad mount |
| | Mitsubishi 12V 160 AMP pad mount |
| Starter | Delco Remy 31MT |
| | Denso 12V |
| Batteries | (2) group 31 750 CCA (min)/1500 CCA total |
| | 1900CCA, 2000CCA, 3000CCA, AGM batteries 1800CC, 2300 CCA |
| Circuit protection | Fused circuits |
| Windshield wipers | Single electric (pantograph) intermittent w/washer |
| Backup alarm | Non-motion detecting |
| | Motion detecting, CA compliant, or white noise |
| Horn | Single electric |
| Telematics | Autocar Advanced Telematics - full installation |

| CAB AND EQUIPMENT | |
|-----------------------------|---|
| Cab construction | Electrocoated (e-coated) steel, full cab immersion (rust prevention coating) |
| Cab dimensions (outside) | Raised roof, 52" wide x 71" deep (w/o rear door) x 78" high (deck to roof) |
| Cab doors | Left side hinged door w/manual crank window, aluminum sliding rear door |
| | Rear door protector |
| Rear door opening (useable) | 24" wide x 72" high |
| Cab floor | Sweep out floor w/durable mat |
| Cab dash | Steel wrap around |
| Overhead console | Steel |
| Cab mounting | 4 point, rear dual (2) air suspensions |
| | 3-point spring |
| Cab tilt | Electric over hydraulic |
| Windshield | Tinted, laminated windshield |
| Rear glass | Tinted, tempered |
| | Laminated, Premier high impact-resistant window |
| Mirrors | Dual SST west coast mirrors |
| | Heated primary, motorized primary, convex |
| Cab climate control system | 44,000 BTU fresh air heater |
| | Air conditioning |
| Steering column | Fixed |
| Steering wheel | Tilt/telescopic |
| Seat | 18 inch 2-spoke |
| | Air suspension, mid-back without fore/aft isolation Air suspension, mid-back with fore/aft isolation |
| Seat covering | Black Cordura Plus® cloth fabric Vinyl seat cover |
| Seat belt | 3-point orange extended length |
| Dome light | Switch on dash |
| Power ports | (1) 12V & 2 USB |
| Air horns | Mounted top right side of cab |
| Translucent sun visor | Translucent-single |
| Conspicuity tape | White BOC, red/white end of frame |

ACTT 6X4

AUTOCAR TERMINAL TRACTOR - OFF-ROAD

| LIGHTING | |
|-----------------------------------|---|
| Headlamps | Low/high halogen |
| | LED Headlights, Spot-style headlights, direct wired |
| Backup light, stop & turn signals | LED stop & turn, incandescent backup, shock resistant mount |
| | LED spot lights, alternate positioning |
| BOC 5th wheel light | Incandescent, shock resistant mount |
| | LED BOC light |
| Marker and side turn signals | LED |

| PAINT | |
|---------|----------------------------|
| Cab | White |
| | (Customer specific colors) |
| Chassis | Black |
| | (Customer specific colors) |
| Bumper | Black |
| | (Customer specific colors) |
| Wheels | White powder coat |
| | (Customer specific colors) |

| BASIC WARRANTIES | |
|---------------------------|---|
| Autocar terminal tractor | 1 year or 3,000 hours whichever occurs first, parts & labor |
| Frame | 7 years or 20,000 hours whichever occurs first |
| Cummins industrial engine | QSB - 2 years parts & labor (2,000 hours) |
| Allison transmission | 3 years parts & labor |
| | 5 year optional |
| Dana axles | 3 years parts & labor |
| Meritor axles | (24-160 only) 6 months, parts only |
| | 2 years parts & labor |

| VEHICLE RATINGS | |
|----------------------------|------------|
| Vehicle tare weight, front | |
| Vehicle tare weight, rear | |
| GAWF | 14,500 lbs |
| GAWR | 40,000 lbs |
| GCW | 80,000 lbs |

| OPTIONAL EQUIPMENT | | |
|---|---|--|
| Air Dryer (ADIP, AD-9, Wabco1200) | Glad-hand and 7-way cable storage | Cab fan(s) |
| Fuel/water separator w/heater | Battery disconnect switch | AM/FM radio/CD w/ aux input, speakers & antenna |
| Engine block heater | Air restriction indicator w/dash light | 5# ABC fire extinguisher |
| Oil pan heater | Amber beacon light | Triangle kit |
| Beavertail/frame extension/kingpin guides | Spot/work/flood lights | Lever start, no key/pushbutton start |
| Front axle mudflaps | Rear door laminated glass or high impact resistant window | Double blink strobe light, other strobe/beacon options |
| Rear axle mudflap (front) | Training seat | Air horn |
| Rear flexible fenders | Auto lube systems | No driver door |
| Fender skirt/splash protector | Trailer stops/full cab guard | Lever start, no key/pushbutton start |
| Glad hand buckets | Dock bumpers (cab) | Double blink strobe light, other strobe/beacon options |
| Additional engine tunnel insulation | Additional decking, side cab catwalk | Trailer rapid fill system |
| 360 degree swivel trailer light | Diamond plate cab floor | Pneumatic 5th wheel lockout |
| Premium seating options (swivel, heated) | RH deck access steps | Cab document storage |
| Rear axle differential lock | Dollymaster, pintle hook options | RH deck access steps |
| | Trailer hand brake | Autocar autopark system |

| OPERATORS CONTROLS |
|--|
| Park brake - push/pull |
| Headlamps |
| Turn signal - column mounted |
| Brake pedal (dual pedal optional) |
| Accelerator pedal |
| 5th wheel height control |
| 5th wheel lock |
| Transmission gear selector - Push button |

| CAB INSTRUMENTATION |
|---|
| Cluster with Information/Diagnostic display |
| Speedometer |
| Engine oil pressure |
| Coolant temperature |
| Transmission oil temperature |
| Fuel level/DEF level |
| Primary (A) air pressure |
| Secondary (B) air pressure |
| Hour meter |
| Voltmeter |

| CAB WARNING DEVICES |
|--|
| Park brake |
| High beam |
| Turn signal |
| Low fuel |
| Low air |
| Seat belt |
| DPF |
| HEST |
| Air restriction indicator |
| Filter with water in fuel indicator |
| Fifth Wheel height indicator/lock indicator (optional) |