



# ACMD<sup>®</sup> 6X4

AUTOCAR MEDIUM DUTY • CLASS 8

## ACMD<sup>®</sup> 6X4 • CLASS 8

Representative Medium Duty Specifications.

Your truck will be custom-engineered for your application

ALL DIMENSIONS IN INCHES

### CAB INTERNAL DIMENSIONS

- Foot well to Roof..... 60.77"
- Windscreen to Rear of Cab....68.81"
- Door to Door (interior).....71.32"
- Volume behind seats.....854.69"<sup>2</sup>

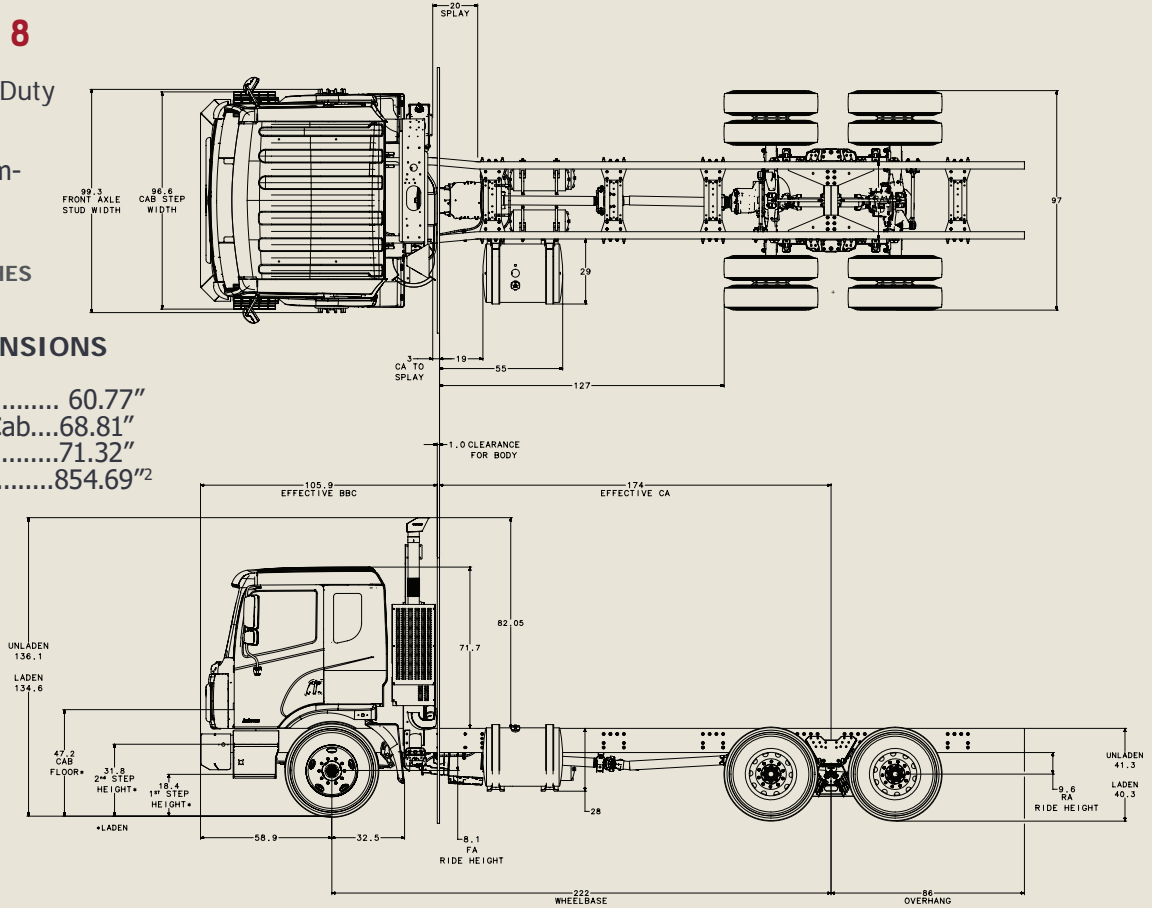
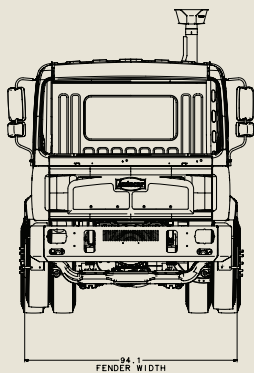

### BASE MODELS / STANDARDS

Steering:	Left hand drive std. , Right hand drive & Dual drive option
BBC:	105.9" With Vertical System, 100.0 With Horizontal System
FOH / Bumper to C/L Front Axle:	58.9"
CA / CT:	Wheelbase - 48" Diesel / - 42" CNG
FAWR, (Min.):	12,000 lbs.
RAWR, (Min.):	40,000 lbs.
GVWR, (Min.):	52,000 lbs.
Wheelbase:	165"
* Est. Base Model Front Axle Weights*:	8610 lbs.
* Est. Base Model Rear Axle Weights*:	4350 lbs.
* Est. Base Model Chassis Weights Total:	12960 lbs.
	* Weight will vary w/wheelbase, RFOH and optional equipment specified

### CHASSIS SPECIFICATIONS

Construction:	Huck bolted, "C" - channel ladder
Wheelbase Min. - Max:	150" - 224"
AF / RFOH Length Min. - Max:	21.58" - 110"
Frame Rail Dimensions:	.375" x 3.25" x 10.75", (120KSI)
RBM:	2.68M
SM:	18 lbs.
Formed .25" x 9.85" Channel Liner:	Standard
Front Tow Loops:	2 recessed behind front bumper
Fuel Tank Size:	Steel/Aluminum 50, 75, 100, 150 or 5 gallon poly-temporary
Location, Fuel Tank(s):	Temporary fuel tank (std.) or LH or RH frame rail
Fuel/Water Separator - Heated (Opt):	Parker 490RPMC series / heated OPT Fleetguard FS series / heated (OPT)

CAB SPECIFICATIONS	
Construction:	Welded & stamped steel construction, E-coated prior to painting
Windshield:	2,785 square inch, laminated & curved
Cab Glass:	Tempered safety, tinted (VLT 75%)
Windows, Cab Door:	Power, roll up - tinted (VLT 80%)
Cab Floor:	Wear resistant mat with foam back with HD floor mat, insulated backing
Cab Tilt System:	Hydraulic / Electrical power assist, auto locking
Steering System:	Integral hydraulic power assist
Steering Column:	Tilt/Telescoping w/integral turn signal
Steering Wheel:	16"/18" Diameter, 2 spoke, vinyl wrapped
Cab Mirrors - West Coast Type:	4 - Chrome or Black housing, 1 large flat and 1 lower rectangular convex, each side
Seating Configuration:	2 or 3 Person (Optional)
Seat - Driver / LH:	Sears - high back, air ride w/arm rest and lumbar support
Seat - Passenger / RH:	Sears - high back, air ride w/arm rest and lumbar support
Seat Belts:	3 Point, over shoulder and lap
Air Conditioning, Cabin:	Standard, integral HVAC in-dash
HVAC System:	Integral in-dash type, high capacity -Push button - soft touch automatic climate and manual temperature control, positive PSI type system with quick defrost mode. Fresh air and recirculating type with variable 5 speed fan.
Instrumentation:	Large predominant backlit speedometer on center, tachometer & dual air PSI to each side. Smaller less prominent engine oil psi, coolant temp, voltmeter, fuel gauge, warning lamps & Mini Driver Information Center (MDIC) all in row, that includes: clock, odometer, tripmeter, engine hour meter and trip engine hour meter.
Front Bumper:	Formed steel or HD formed steel, w/integral headlights
Headlights:	LED large single rectangular type
ICC Marker and Turn:	Amber incandescent or LED turn and marker
DOT Certification:	FMVSS standard, CMVSS optional
Paint, Cab (White - Std.):	Dupont, (DPSS) polyurethane enamel
Paint, Front Bumper:	Same color as cab or custom
Paint, Chassis:	Semi-gloss black, polyurethane
Paint, Disc Wheels:	White, powder coated

REAR DRIVE AXLE / SUSPENSION SELECTION	
Rear Axles (STD):	Meritor MT40-14X
Rear Axle (opt):	Meritor RT46-160
Max. RAWR:	46,000 lbs.
Spring Suspension:	HMX-400 / HMX-460
Air Suspension (Opt.):	HAS-402 / PAX-EX 462

FRONT AXLE / SUSPENSION SELECTION	
Front Axles (std):	Dana E-1202W
Front Axles (opt):	Dana E-1322W / Dana E-1462W
Front Axles (opt):	Meritor MFS-14 / Meritor MFS-16 / Meritor MFS-18
Max. FAWR:	12,000 - 18,000 lbs.
Steering Syst.:	Dual / LH / RH

DRIVE SPECIFICATIONS	
Engine - Diesel:	Cummins L9 / US EPA 26
Available L9 Diesel HP Ratings:	260, 270, 300, 330, 350 and 360 hp
DEF Tank Capacity / Location:	6.25 or 12.5 Gallon, LH behind front fender/RH over front fender
Engine - CNG:	Cummins-Westport L9N / US EPA 26
Available CNG / L9N HP Ratings:	250, 260 and 300 hp
Air Compressor:	Cummins 18.7 CFM
Air Dryer:	Wabco w/heat
Starter:	Delco 39MT W/OCP
Alternator:	Delco 12V 160 amp or 200 amp
Batteries (2) 12V:	1500 / 1900 / 2000 CCA, Group 31 ECL M/F
AGM Batteries (2) 12V:	1650 / 1800 / 2300 CCA, Group 31 ECL M/F
Transmission:	Allison 3000RDS or 3500RDS
Number of Speeds:	1 Reverse, 6 forward
Transmission Shifter:	Push button, shift pad - LH or center
Driveshaft's:	Dana-Spicer 1710HD half round yoke
Radiator Square Inch Core:	725 square inch down flow
Charge Air Cooler:	Welded, aluminum construction
Air Cleaner Size:	13" single stage, safety-filter optional
Exhaust Outlet Location:	LH, street side vertical / RH Horizontal curb side

FRONT AND REAR AXLES	
Front Axles:	Dana E-1202W
Max. Cramp Angle - Steer:	47 Deg. +/-
Steel Disc Wheels - Hub Piloted:	Qty. 2; 22.5" x 8.25", 5 hand hole
Tire Size:	11R22.5(G)
Front Brakes (Q Plus):	16.5" x 6" QP
Front Suspension (Flatleaf):	12,500 / 13,200 / 14,500 / 16,500 / 18,800 lbs.
Rear Axles:	MT40-14X
Axle Speeds:	1 Speed
Steel Disc Wheels - Hub Piloted:	4; 22.5" x 8.25", 5 hand hole
Tire Size:	11R22.5(G)
Rear Brakes:	16.5" x 8.62" QP
Rear Suspension - Steel Flat Leaf:	HMX-400 EX or 460 EX
OPT / Rear Suspension - Flat Leaf:	PAX EX 462
OPT / Rear Suspension:	HAS 402
Brake System - Chassis:	FMVSS 121, Dual air brake
ABS Systems:	Wabco, 6S/4M
ATC Systems:	ATC optional

ENGINE AND TRANSMISSION	
Engine Model:	Cummins L9N rated from 250 HP to 300 HP / 895 - 1166 lb-ft, 2500, 3000, 3500 RDS Cummins L9 rated from 260 HP to 300 HP / 977 - 1150 lb-ft, 2500, 3000, 3500 RDS