



DC-64T™

SEVERE-DUTY CONVENTIONAL • CLASS 8

SEVERE-DUTY CONVENTIONAL PURPOSE-BUILT TRACTOR

Representative DC-64™ Specifications.

Your truck will be custom-engineered for your application.

ALL DIMENSIONS IN INCHES

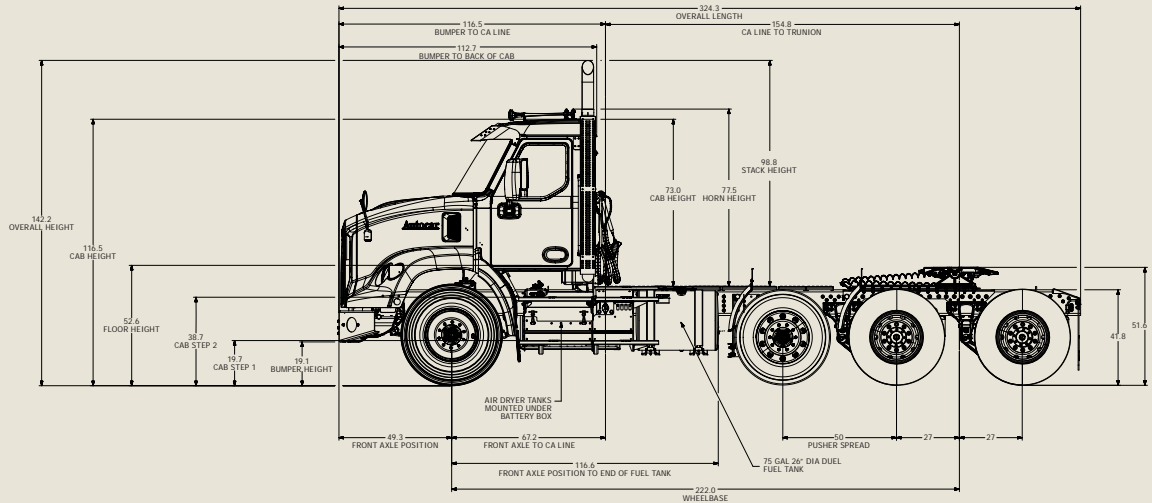
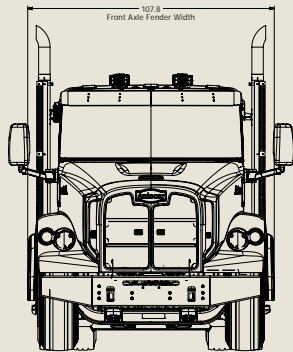
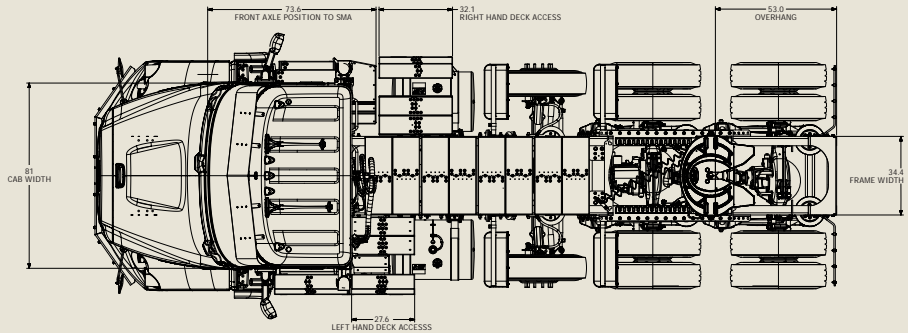

CONFIGURATION	
Steering	13.2k to 14.6k - Single left hand drive with single M100 Sheppard gear 18k to 20k - Single left hand drive with dual M100 Sheppard gears
Front Axle Position (FAP)	49" Set Back
FAWR	13,200 lbs - 20,000 lbs
RAWR	40,000 lbs - 46,000 lbs
Wheelbase	171" - 297" (3" Increments)
Overhang	52" - 100"

ENGINE MODELS	MAXIMUM HP	MAXIMUM TORQUE	GOVERNED SPEED
Cummins X12 Diesel	350HP	1350 LB-FT	2000 RPM
	380HP	1450 LB-FT	2000 RPM
	410HP	1450 LB-FT	2000 RPM
	430HP	1650 LB-FT	2000 RPM
	455HP	1550 LB-FT	2000 RPM
	475HP	1700 LB-FT	2000 RPM
	500HP	1700 LB-FT	2000 RPM

FRONT AXLE AND EQUIPMENT	
Front Axles	Hendrickson Steertek NXT 13.2k, 14.6k, 18k, 20k
Front Suspension	13,200-20,000 lbs. Taper leaf springs
Wheel Cut	Up to 50 degrees
Front Wheels	22.5 x 8.25" through 22.5 x 13.0" Steel disc and polished aluminum
Front Tire Sizes	11R22.5 through 425/65R22.5
Front Hubs	Conmet Pre-Set plus Hubs
Front Brakes	EX-225 air disc brakes standard

ENGINE AND EQUIPMENT	
Engines	Cummins X12 rated from 350-500 hp/1350 lb-ft - 1700 lb.ft with optional REPTO
Engine Brake	X12 with Integrated Jake Brake - 3 Positions
DEF Tank Capacity / Location	12 gallon mounted driver's side integrated with Battery Box
Starter	Delco Remy 39MT w/OCF
Alternator	Delco Remy 160/200 AMP
Batteries Chassis mounted (max 3)	2250-2850 CCA, Group 31 ECL M/F, Flooded Lead Acid or optional AGM

ENGINE AND EQUIPMENT	
Batteries In-Cab (max 3)	2475 CCA, Group 31 ECL M/F, AGM only
Transmission	Allison Automatic 4500, 4700 RDS series
Transmission Shifter	Push button, shift pad mounted on center console
Number of Speeds	6 Speed, 1 Reverse 7 speed, 2 Reverse for 4700 model only
Air Cleaner	Opti-air 1300 series, integrated pre-cleaner with optional safety filter
Radiator	1,380 square inch down flow
Exhaust Outlet Location	RH curb side single canister with horizontal diffuser or vertical stack (Diesel only) with Turn out
Additional Exhaust Outlet Location	Optional LH Dummy vertical stack with Turn out

CHASSIS AND EQUIPMENT	
Construction	"C"-channel Frame rails Heat treated to 160 KSI - huck bolted ladder assembly
Frame Rail Dimensions	Frame flange: 4.1" Frame thickness: 7/16"
Frame Rail Height Dimensions	10.875" - RBM: 3.7M LBF.IN up to 4.5M LBF.IN with optional 120KSI liner
	11.25" - RBM: 3.9M LBF.IN up to 4.7M LBF.IN with optional 120KSI liner
	12.25" - RBM: 4.4M LBF.IN up to 5.3M LBF.IN with optional 120KSI liner
Front Tow Loops	Standard 2 pins recessed behind front bumper - 80,000 lbs. towing capacity Optional Heavy duty Single tow pin recessed behind front bumper - 150,000 lbs. towing capacity (Only available on SFA)
Fuel Tank Size	45-125 gallon polished aluminum - 22" or 26" diameter
Location, Fuel Tank(s)	LH frame rail under cab steps
Fuel/Water Separator	Fleetguard FS series with optional heater & H2O probe Davco Filters with optional heater & H2O probe Parker GreenMax
Pusher Axles	Hendrickson Compositlite 13.5/20K available in steerable and non-steerable Watson & Chalin SL 8/10K available in steerable only
Fifth Wheel	SAF Holland FW35/FW70 with 2" King Pin Various 5th wheel loactions - 6" rearward to 36" forward of Bogie center Fixed and Slide options available - slide range 24"-72"
Decking	Aluminum rear decking
Decking steps	LHS & RHS BOC access steps standard
Trailer electric and pneumatic couplings	Flexible Trailer pneumatic supply hoses and electric wiring located BoC
Fenders	Rear tandem and pusher axle quarter fender options available

REAR AXLE AND EQUIPMENT	
Rear Axles - Meritor (Tandem)	MT40-14X / RT46-160 / RT46-164EH
Rear Suspension - Hendrickson	Haulmaax EX 460 Primaax EX 462 Air ride
Rear Wheels	22.5 x 8.25" through 24.5 x 8.25" Steel disc and polished aluminum
Rear Tires	11R22.5 through 315/80R22.5, including 24.5" wheels

REAR AXLE AND EQUIPMENT	
Rear Brakes	Meritor Q-Plus 16.5 x 7/8.62" drum or EX-225 air disc brakes
Braking Systems	WABCO ABS 6S/6M standard with ATC and ESC
Driver Safety	Optional Advanced Driver Assist Systems (ADAS) available: ESC and Rollover Stability Control ZF Onguard Max - Forward Collision Warning & Lane Departure Assist ZF SRR - Side Radar for Blind Spot Detection

CAB AND EQUIPMENT	
Construction	Welded and stamped galvanised steel construction w/corner castings, E-coated prior to painting
Windshield	One piece, raked for visibility, laminated and curved
Cab Glass	Tempered safety, tinted (VLT 75%)
Windows, Cab Door	Power windows standard Manual door locks standard with optional power locks driver and passenger side
Cab Floor	Heavy duty abrasion resistant mat with optional aluminum diamond plate insert at heel point
Cab Suspension	Twin air bag suspension w/lateral stabilizer bar
Steering Column	Tilt/telescopic
Steering Wheel	18" diameter, polyurethane or black leather with red stitching wrapped wheel, 2 spokes powder coated black or chrome
Cab Mirrors	Powered Door mounted 14x7" main mirrors and 4x3" convex mirror with break-away head, black or chrome housing, heated/marker light options
Seating Configuration	2 or 3 Person (bench seat)
Seat - Driver/LH	Bostrom T914 air ride hi-back with manual lumbar and optional arm rest, black mordura
Seat - Passenger/RH	Same as driver with optional 2-person low back bench seat
Seat Belts	3 point, over shoulder and lap, adjustable shoulder height
Air Conditioning, Cabin	Standard - with 4 dash and 2 under-dash vents
HVAC System	Standard - integral high capacity system incl HVAC controller with rotary controls. 360 degree adjustable vents. Fresh air and recirculating type with variable 4 speed fan
Instrumentation	Comprehensive and customizable selection of analog and soft gauges. Plus, Autocar's revolutionary 7" digital display which shows any gauge with an out-of-standard condition, several modes including a "No-Distracted" mode for safety, and One-Touch Diagnostics to speed resolution of maintenance issues or fault conditions
Front Bumper	Painted or chromed steel w/integral fog light option
Headlights	LED 7" round with Daytime running lights
ICC Marker and Turn	LED
DOT Certification	FMVSS standard, CMVSS optional
Paint, Cab (White - Std)	Interior steel surfaces painted exterior color
Paint, Chassis	Semi-gloss black, polyurethane, optional colors available
Paint, Disc Wheels	White STD, grey optional powder coated.